

SAILOR

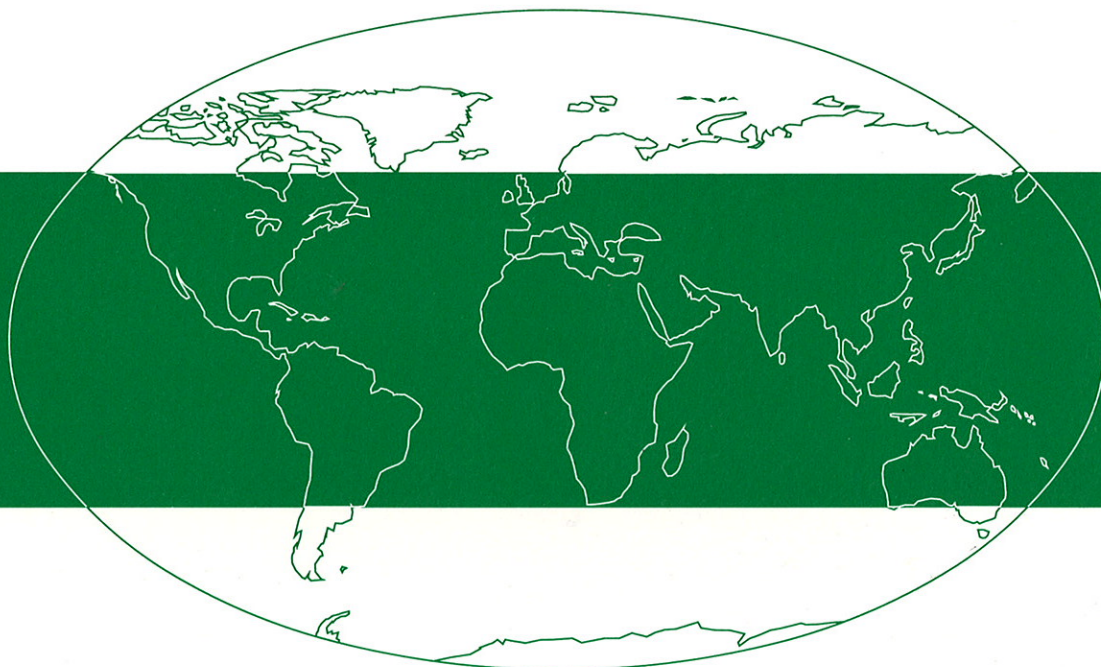

TECHNICAL MANUAL
FOR
COMPACT HF SSB AT2110



S.P. RADIO A/S · AALBORG · DENMARK



S.P. RADIO A/S

PORSVEJ 2 • DK-9200 AALBORG SV • DENMARK
TEL. INT. + 45-98180999 • TELEX 69 789 SPRAD DK • TELEFAX + 45-98186717

CONTENTS

- 1 INTRODUCTION**
 - 1.1 GENERAL DESCRIPTION
 - 1.2 TECHNICAL DATA
 - 1.3 PRINCIPLE OF OPERATION AND BLOCK DIAGRAM

- 2 INSTALLATION**
 - 2.1 MOUNTING POSSIBILITIES/DIMENSIONS AND DRILLING PLAN
 - 2.2 ELECTRICAL CONNECTION
(FOR CABLE SPECIFICATIONS SEE MANUAL T2130)

- 3 SERVICE**
 - 3.1 MAINTENANCE
 - 3.2 ALIGNMENT INSTRUCTIONS
 - 3.3 PROPOSAL FOR NECESSARY MEASURING INSTRUMENTS
 - 3.4 TROUBLE SHOOTING
 - 3.4.1 REPLACEMENT OF COMPONENTS
 - 3.4.2 REPLACEMENT OF MODULES
 - 3.5 PERFORMANCE CHECK
 - 3.6 FUNCTION CHECK
 - 3.9 SERVICE PROGRAMMES

- 4 MECHANICAL DISASSEMBLING**
 - 4.1 MECHANICAL DISASSEMBLING AND MODULE LOCATION

- 5 CIRCUIT DESCRIPTION AND SCHEMATIC DIAGRAMS**
 - 5.1 MAIN BOARD (MODULE 1) SP NO. 625651
 - 5.3 CONNECTION AND INTERFACE UNIT (MODULE 3)
SP NO. 625653

- 6 PARTS LIST**

CONTENTS

1. INTRODUCTION
- 1.1. GENERAL DESCRIPTION
- 1.2. TECHNICAL DATA
- 1.3. PRINCIPLE OF OPERATION AND BLOCK DIAGRAM

1. INTRODUCTION

The SAILOR Compact HF SSB AT2110 is an automatic tuning aerial coupler for transmitter T2130 in SAILOR Compact HF SSB Programme 2000.

SAILOR Compact HF SSB Programme 2000 is a powerful, advanced, high technology short wave communication system, which is extremely easy to operate.

SAILOR HF SSB AT2110 has been developed on the basis of S. P. Radio's many years of experience with construction of aerial couplers for use outdoors in maritime environments.

It has the same high reliability as all SAILOR equipment is known for.

SAILOR HF SSB PROGRAMME 2000 CONSISTS OF THE FOLLOWING UNITS:

RE2100: Control unit with integral receiver and exciter.

T2130: 250W PEP SSB transmitter with integral power supply for RE2100. Supply voltage 24V.

AT2110: 250W PEP aerial coupler for use outdoors.

N2160: 12V DC power supply for T2130.

N2161: 110/220/240V AC, 50 Hz power supply for T2130.

1.1. GENERAL DESCRIPTION

SAILOR HF SSB AT2110 is a 250W PEP aerial coupler.

SAILOR HF SSB AT2110 is able to tune aeriels from 7 to 15 metres.

SAILOR HF SSB AT2110 is able to tune in the entire frequency range from 1.6 MHz to 30 MHz.

SAILOR HF SSB AT2110 has a waterproof cabinet.

SAILOR HF SSB AT2110 has a high reliability due to few active components.

SAILOR HF SSB AT2110 tunes automatically, controlled from the microprocessor in T2130.

SAILOR HF SSB AT2110 tunes typically for less than 2 secs.

SAILOR HF SSB AT2110 has small dimensions and low weight.

1.2 TECHNICAL DATA

(complies with SOLAS, ITU, CEPT, MPT, DOC, FTZ, KSR, FCC)

GENERAL

Frequency Range:	Receiver: 100 kHz to 30 MHz Transmitter: 1.6 MHz to 30 MHz
Modes:	J3E (USB/LSB), R3E and H3E (AM)
Channel Capacity:	100 user defined quick-select channels and ITU defined channels in the maritime bands. Each channel contains both RX and TX frequency and mode settings.
Scanning Facilities:	10 scanning programmes, each able to contain 128 pairs of frequencies.
Distress Call:	Quick selection of 2182 kHz Built-in two tone alarm: 1300 Hz and 2200 Hz with a duration of 45 secs.
Operating Temperature Range:	-15°C to +55°C
Frequency Stability:	Better than 0.34 ppm
Primary Voltage:	24V DC - 10% +30%
Current Drain:	Receiver (standby) 0.9A Transmit voice 7A Transmit two-tone 13A
Aerials:	from 7 - 15 m

TRANSMITTER T2130

Power Output:	250W PEP \pm 1.4 dB (T2130/I 240W PEP max.)
Intermodulation:	better than 32 dB below PEP
Spurious Emission:	better than 67 dB below PEP
Harmonics:	better than 43 dB below PEP or better than 67 dB below PEP with aerial coupler AT2110
Carrier Suppression:	better than 46 dB below PEP
Audio Response:	350 Hz to 2700 Hz at -6 dB

RECEIVER RE2100

Receive System:	Double conversion super heterodyne 1st IF 70 MHz. 2nd 10.73 MHz
Selectivity:	J3E (SSB) 350 Hz to 2700 Hz at -6 dB H3E (AM) \pm 3.3 kHz at -6 dB

1.2 TECHNICAL DATA cont.:

Sensitivity:	J3E (SSB) <10 dB/uV for 20 dB SINAD H3E (AM) <24 dB/uV for 20 dB SINAD
Spurious and IF Rejection:	better than -70 dB
Cross Modulation:	better than 90 dB/uV (CEPT method of test)
Desensitization:	better than 100 dB/uV (CEPT method of test)
AGC:	less than 2 dB audio level change from 10 dB/uV to 80 dB/uV. Fast attack, slow release time.
Intermodulation:	better than 90 dB/uV (CEPT method of test)
Spurious Emission:	better than 1 nW into dummy aerial
Clarifier:	±150 Hz in steps of 10 Hz
Squelch:	Voice activated, opens for SINAD >6 dB
Audio Power:	5 Watt, 8 ohm, less than 10% distortion 10 Watt, 4 ohm, less than 10% distortion

AERIAL COUPLER AT2110

Power:	250W PEP
Aerials:	7 - 15m
Temperature Range:	-25°C to +70°C
Tuning Time:	Typically less than 2 secs (learn mode typ. 30 secs)

ACCESSORIES

Loudspeaker:	H2054 see special brochure H2074 see special brochure
Power Supplies:	N2160 Input supply: 12V + 30% - 10% For more information see the manual for N2160 N2161 Input supply: 110V - 127V - 220V - 240VAC Input frequency: 50 - 60 Hz For more information see the manual for N2161
Weight:	RE2100: 4.5 kg T2130: 14 kg AT2110: 4.5 kg

Dimensions:

1.3. PRINCIPLE OF OPERATION AND BLOCK DIAGRAM

SAILOR Compact HF SSB AT2110 is a 250W PEP aerial coupler in SAILOR Compact HF SSB Programme 2000. It contains the following circuits.

CONNECTION AND INTERFACE UNIT

This unit contains a bus receiver, specially constructed to work in noisy environments. The bus receiver is followed by a detector/latch and shift registers, which controls the relay drivers.

MAIN BOARD

This unit contains the components for the aerial matching. It also contains the aerial current detector.

The RF signal from the transmitter T2130 is fed to a transformer, and then through a serial inductor, which is variable in steps, in series with a motor driven variable capacitor. After the variable capacitor there is a shunt capacitor to ground. This capacitor is variable in steps. From here the signal is fed to the aerial relay and then through the aerial current detector circuit to the aerial.

AT2110 A 4-0-25849A

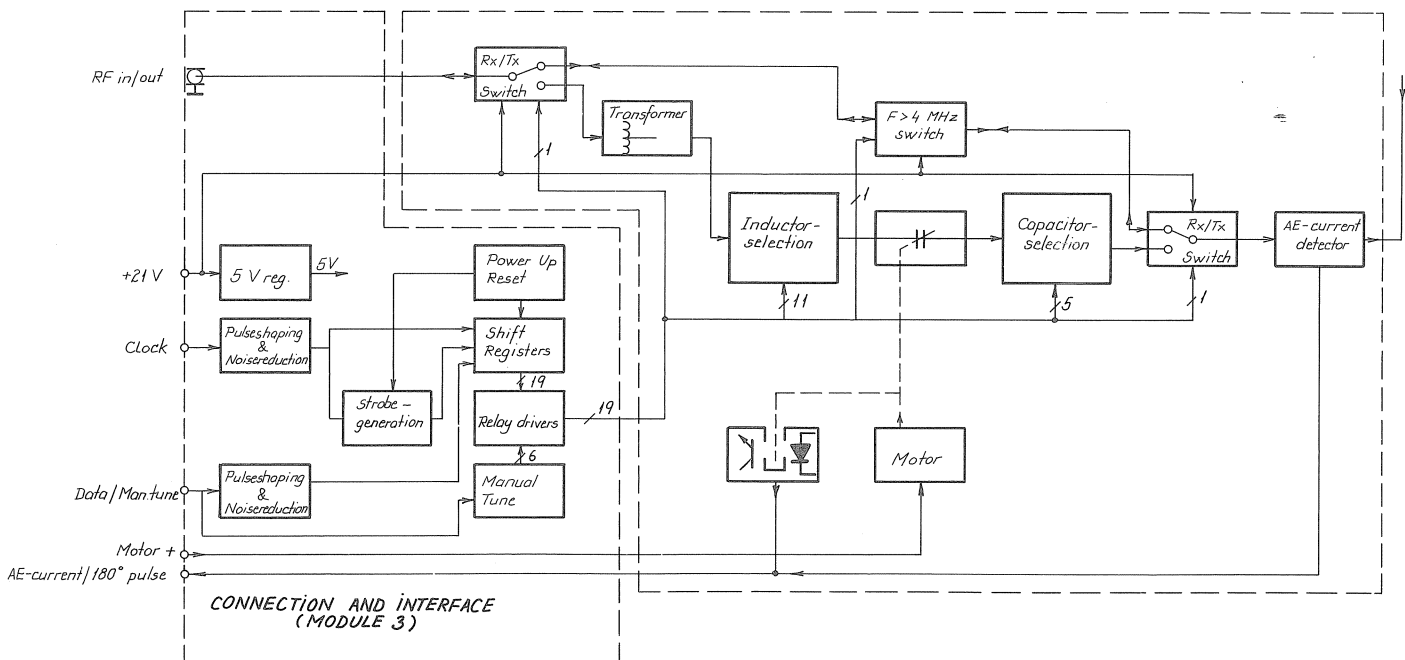

BLOCK DIAGRAM AT2110

CONTENTS

- 2. INSTALLATION
- 2.1. MOUNTING POSSIBILITIES/DIMENSIONS AND DRILLING PLAN
- 2.2. ELECTRICAL CONNECTION
(FOR CABLE SPECIFICATIONS SEE MANUAL T2130)

2.1. MOUNTING POSSIBILITIES/DIMENSIONS AND DRILLING PLAN

AT2110
4-0-25897

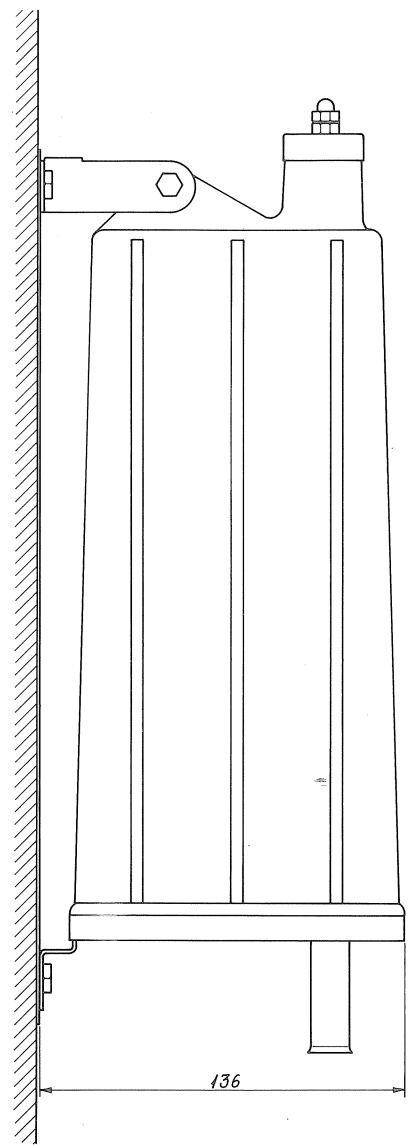
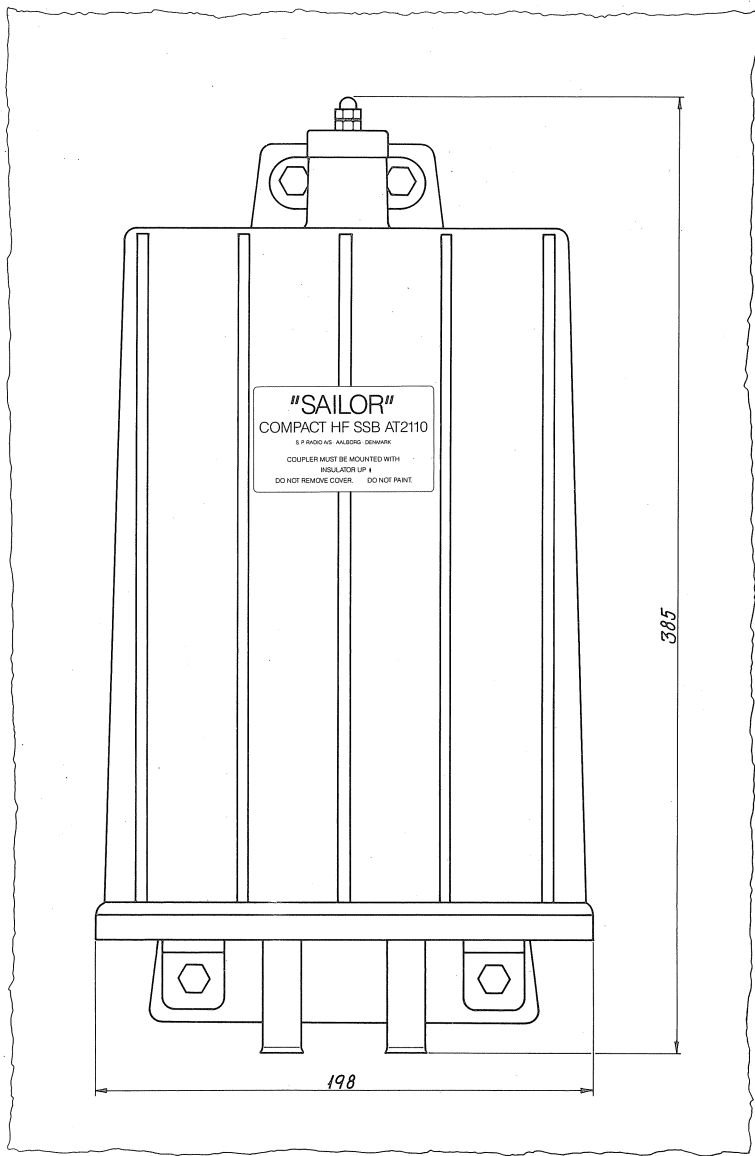

2.1. MOUNTING POSSIBILITIES/DIMENSIONS AND DRILLING PLAN

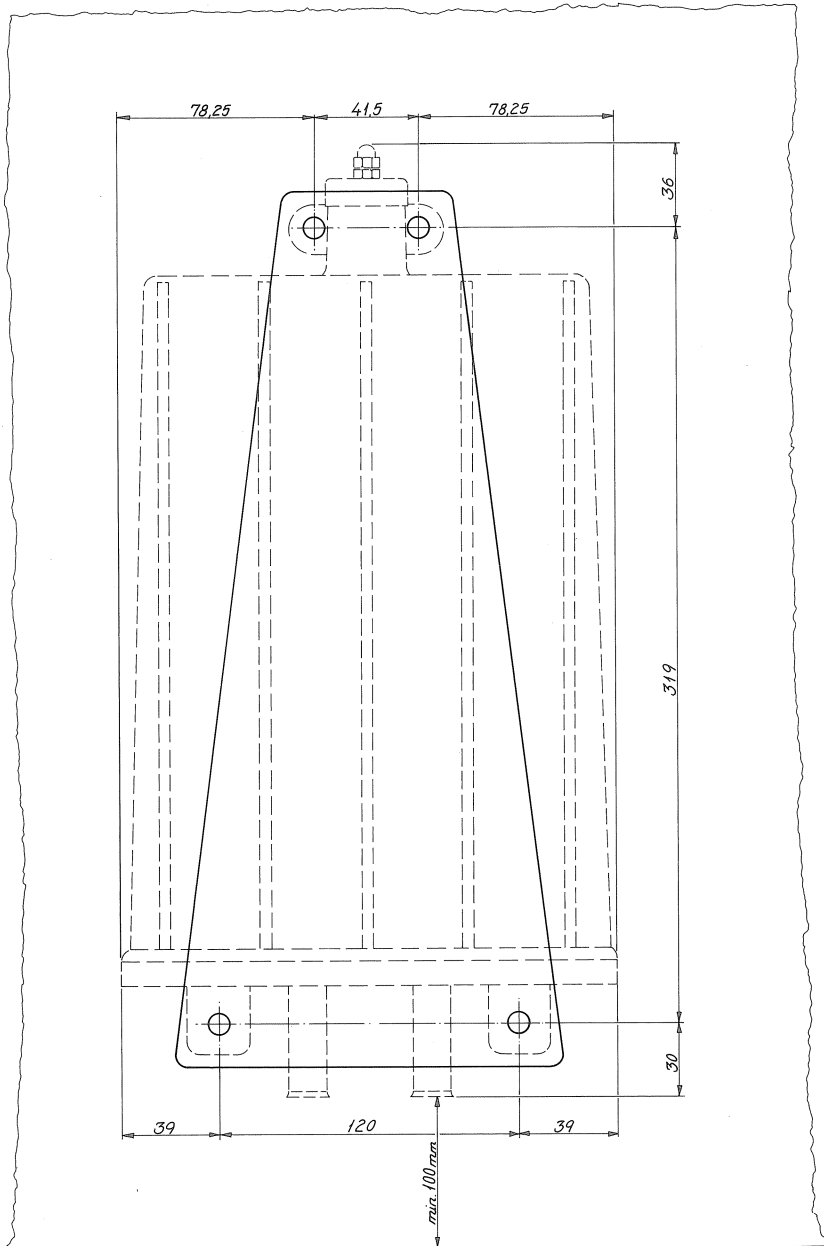

Free space for cable entry.

2.1. MOUNTING POSSIBILITIES/DIMENSIONS AND DRILLING PLAN

AT2110 4-0-26253

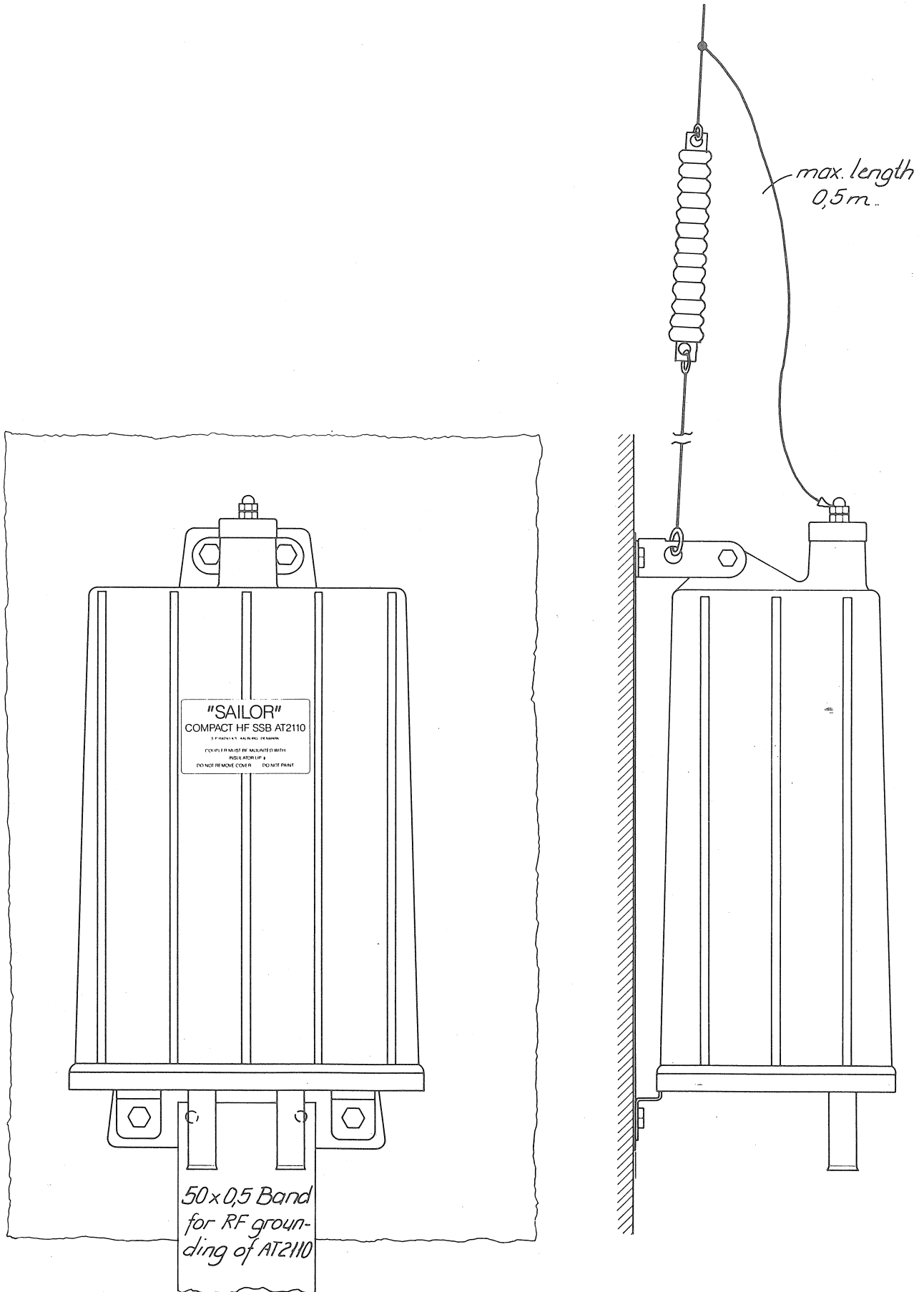

2.1. MOUNTING POSSIBILITIES/DIMENSIONS AND DRILLING PLAN

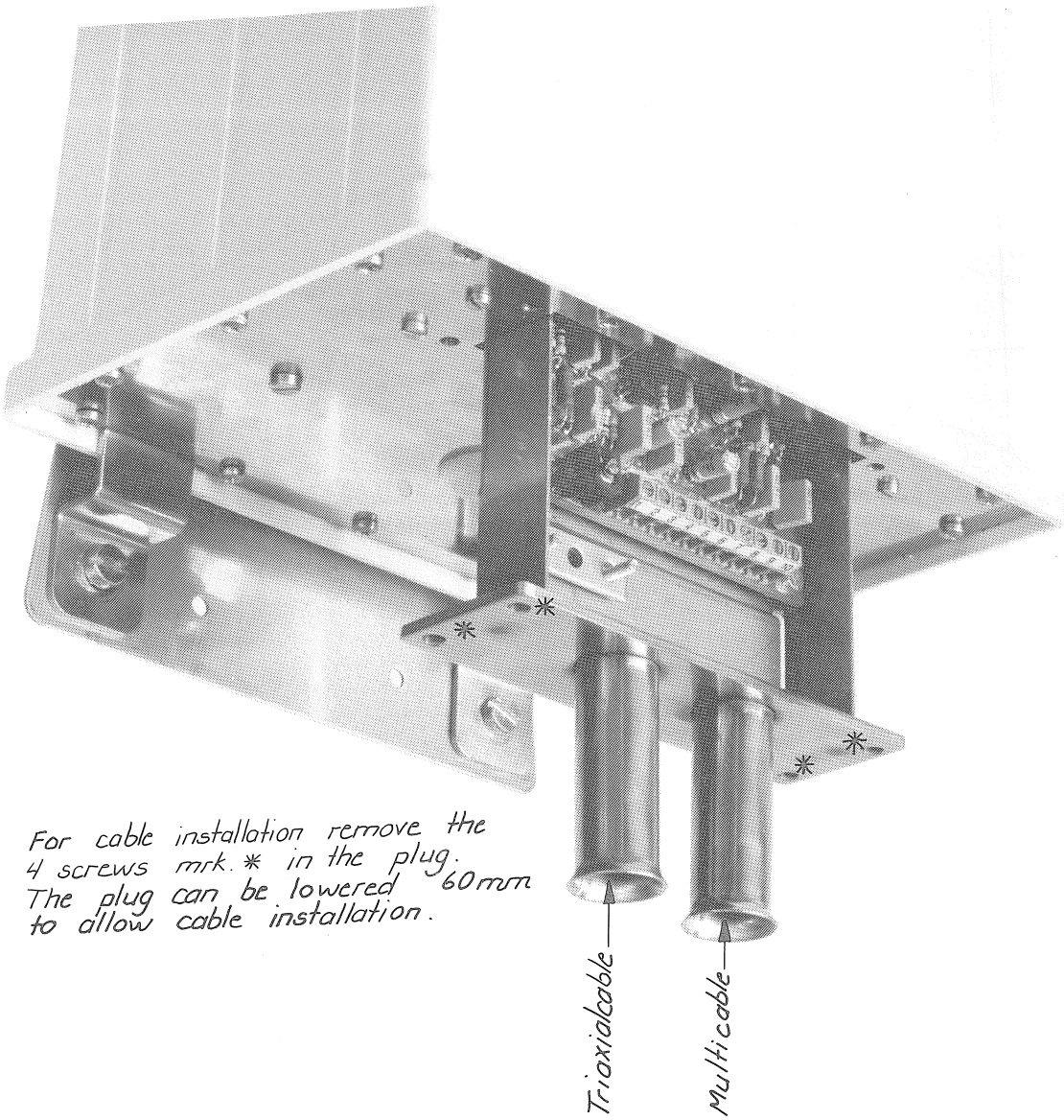

*For cable installation remove the 4 screws mrk. * in the plug. The plug can be lowered 60mm to allow cable installation.*

2.2. ELECTRICAL CONNECTION (FOR CABLE SPECIFICATIONS SEE MANUAL T2130)

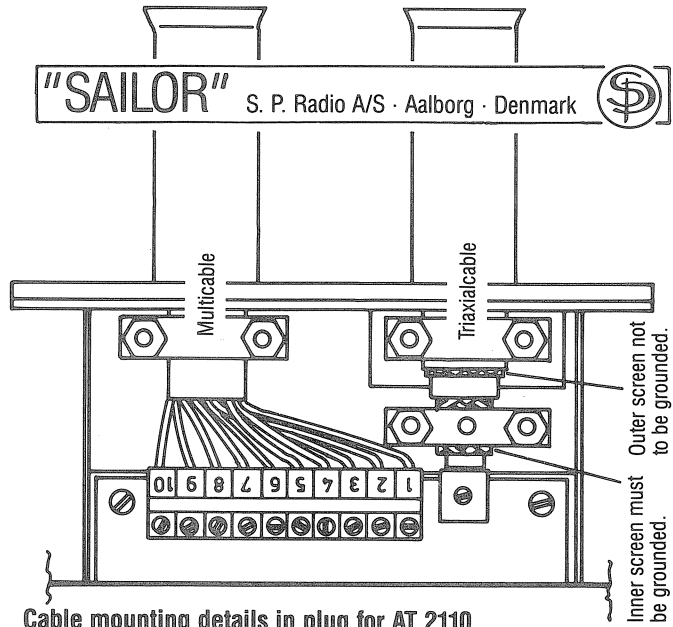

Cable mounting details in plug for AT 2110.

Cable installation:

When removing the 4 screws in the AT2110 plug, the plug can be lowered 60 mm to allow cable installation.

OBS. The plug cannot be removed from the AT2110 during installation

The numbers on the supply terminal block at Connection and Interface PCB in AT2110 correspond with the numbers on the supply terminal block at the Connection Board PCB in T2130.

AT2110 9-3-26101

WIRE STRIPPING FOR TRIAXIALCABLE H1213

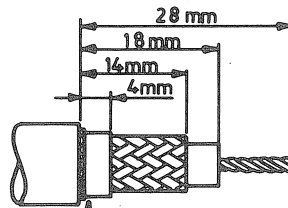

Observe that it can be necessary to isolate outer screen with insulating tape to ensure that it is not grounded.

MULTICABLE: Max. diameter \varnothing 14.5 mm

Length:	Type:
0-50 m	$10 \times 0.5 \text{ mm}^2$
50-100 m	$10 \times 1 \text{ mm}^2$

CONTENTS

- 3. SERVICE
- 3.1. MAINTENANCE
- 3.2. ALIGNMENT INSTRUCTIONS
- 3.3. PROPOSAL FOR NECESSARY TEST EQUIPMENT
- 3.4. TROUBLE SHOOTING
 - 3.4.1. REPLACEMENT OF COMPONENTS
 - 3.4.2. REPLACEMENT OF MODULES
- 3.5. PERFORMANCE CHECK
- 3.6. FUNCTION CHECK
- 3.9. SERVICE PROGRAMMES

3. SERVICE

3.1. MAINTENANCE

PREVENTIVE MAINTANANCE

If SAILOR AT2110 has been installed in a proper way the maintenance can be reduced to an overhaul at each visit of the service staff. Then inspect the set, the antenna, cables, and plugs for mechanical damages, salt deposits, corrosion, and any foreign material. Owing to its traditional structure, the SAILOR AT2110 has a long lifetime, but it must always be carefully checked at intervals not exceeding 12 months - dependent on the conditions under which the set is working. The set must be brought to the service workshop to be tested.

3.2. ALIGNMENT INSTRUCTIONS

INTRODUCTION

The measuring values indicated in chapter 5. CIRCUIT DESCRIPTION AND SCHEMATIC DIAGRAMS are typical values and as indicated it will be necessary to use instruments in absolute conformity with the below list:

3.3. PROPOSAL FOR NECESSARY MEASURING INSTRUMENTS

Tone Generator type PM5107	PHILIPS
Electronic Multimeter type PM2505	PHILIPS
RF Directional Wattmeter Model 43	BIRD
Oscilloscope type PM3216	PHILIPS
Dummy load 50 ohm/250W	
Dummy Load 10 Ohm/250 pF	SAILOR H228
Power Supply 21-32V, 20A	

3.4. TROUBLE SHOOTING

SAILOR Compact HF SSB system has built-in self-diagnostic service system, which is a great help in locating a fault.

When a fault is detected an error message will be displayed in the RE2100 display.

The following description will help you to find the defective unit or module.

Trouble-shooting should only be performed by persons with sufficient technical knowledge, who have the necessary measuring instruments at their disposal, and who have carefully studied the operation principles and structure of SAILOR AT2110.

The first thing to check is whether the fault is somewhere in the antenna circuit or power source.

When measuring in the units, short-circuits must be avoided as the transistors would then be spoiled.

LOCATING THE FAULTY MODULE

Error Messages, Description

The error messages displayed in the RE2100 display are technically described in the following.

70. Motor Circuit Error (AT2110)

An error is detected in the circuitry controlling the tune motor M01 in the AT2110. The TX-processor has not detected the '180° pulse' from the AT2110.

The error may be one of several possibilities:

If the tune motor M01 starts running immediately after the power is switched on at the RE2100:

- Check the level of the '180° PULSE/AE-CURRENT' at ST01 pin 3, on the Connection Board (6) in T2130.

If the level is high (approx. 15 Volt):

The error is probably in the AT2110:

- Check the '180° PULSE/AE-CURRENT' connection between T2130 and AT2110.
- Check the '180° PULSE/AE-CURRENT' connection in the AT2110.
- Check the light in the optocoupler OC01 on the Main Board (1) in the AT2110. This may be done by measuring the voltage drop across the resistor R26 in the Connection and Interface module (3) in the AT2110.

If the level is low:

The error is probably in the T2130:

- Check the '180° PULSE/AE-CURRENT' connection between the Connection Board (6) and the TX-processor (3) in the T2130.

If the tune motor M01 does **NOT** start running immediately after the power is switched on at the RE2100:

- Check the voltage at ST01 pin 7 when the power is tuned on at RE2100. The voltage should be approx. 16 Volt.

3.4. TROUBLE SHOOTING cont.:

If the 16 Volt is ok:

The error is probably in the AT2110:

- Check the connection to the tune motor M01 in AT2110.
- Check the 'Motor +' connection between the T2130 and the AT2110.

If the 16 Volt is **NOT** present:

The error is probably in the T2130:

- Check the connection between the TX-processor (3) and the Connection Board (6) in T2130.

3.4.1. REPLACEMENT OF COMPONENTS

When replacing transistors, diodes, resistors, capacitors and similar components you must use a small "pencil" soldering iron of 30 to 75 Watt rating. The soldering must be performed rapidly to avoid over-heating, and the use of a tin sucker is recommended, as otherwise there is a risk that both the components and the printed circuit will be spoiled.

3.4.2. REPLACEMENT OF MODULES

If a fault has been found in a module, it may often be worthwhile to replace it and then repair it later on.

3.5. PERFORMANCE CHECK

3.5.1. Check of Relays

1. Select service programme SP-30-2. This will activate RE02 on module (1), see chapter 3.9.
2. Check the rest of the relays up to RE09.
3. Select service programme SP-31-0 and check the rest of the relays.

3.5.2. Check of the Tune Motor

1. Select service programme SP-32-3.
2. Check if the motor is running at low speed.

3.5.3. Check of C02 to C06

1. Check by means of a capacitance measuring instrument that they have the correct values.

3.5.4. Check of Coil L01

1. Check by means of an inductance measuring instrument that the total inductance is 58 uH.

3.5.5. Check of Coil L02

1. Check that the total inductance is 7.5 uH.

3.5.6. Check of the RF Signal

1. Connect the AT2110 to a dummy load 10 ohm in series with 250 pF. Select a frequency close to 2 MHz.
2. Key the transmitter by means of the handset key. Whistle into the microphone and check that the aerial current is more than 2 Amps.
3. Repeat point 2 on a 6 MHz frequency and check that the aerial current is more than 3 Amps.
4. Check in standby position that there is connection from the aerial feedthrough to the receiver for frequencies below 3.9 MHz and frequencies above 4.1 MHz.

3.6. FUNCTION CHECK

The function check is to be carried out when the installation is completed.

3.6.1.

Check that it is possible to tune in all frequency bands (e.g. a high and a low frequency in each of the maritime bands). When doing this, use the functions <TX> and <TUNE>. When you have completed the check, make a test call to a coast station.

3.6.2.

If it is not possible to tune on some frequencies, check the aerial and the surrounding rigs, for resonances or bad connections.

3.9. SERVICE PROGRAMMES

In the following it is assumed that the Service Programme jumper is inserted in the RE2100.

In general, if the RE2100 displays 'Err.0' in a Service Programme, the selected SP does not exist.

Example:

Operator: Key: 20-7 <ENT>
RE2100: Displays: 'SP-20-7'
' Err.0'

Legend: Err.0 = The entered service programme does not exist.

SERVICE PROGRAMMES RELATED TO AT2110

SP-30

Activates AT2110 relays 1-9 one by one, and releases any relay.

Example:

Operator: Key: 30 - (0-9) <ENT>
RE2100: Displays: 'SP-30-(0-9)'
' A. '

Legend: 0 = No relays activated
1-9 = Relays 1-9 activated

A. = Accepted
The T2130 activates the entered AT2110 relay no., other relays are released.

SP-31

Activates AT2110 relays 10-19 one by one.

Example:

Operator: Key: 31 - (0-9) <ENT>
RE2100: Displays: 'SP-31-(0-9)'
' A. '

Legend: 0-9 = Relays 10-19 activated.
A. = Accepted.

The T2130 activates the entered AT2110 relay no., other relays are released.

If the AT2110 is in the system (jumper 5 is inserted in the TX-processor) the following is displayed:

RE2100: Displays: 'SP-25 '
' Err.1 '

3.9. SERVICE PROGRAMMES cont.:

SP-32-0

Resets the AT2110 'Clock' line, 'Data' line and the 'Motor +' line to their normal state.

Example:

```
Operator: Key:          32 - 0 <ENT>
RE2100:  Displays:    'SP-32-0'
                   '  A.  '
```

SP-32-1

Sets the AT2110 clock line high.

Example:

```
Operator: Key:          32 - 1 <ENT>
RE2100:  Displays:    'SP-32-1'
                   '  A.  '
```

SP-32-2

Sets the AT2110 data line high.

Example:

```
Operator: Key:          32-2 <ENT>
RE2100:  Displays:    'SP-32-2'
                   '  A.  '
```

SP-32-3

Sets supply on the AT2110 'Motor +' line, (low speed).

Example:

```
Operator: Key:          32 - 3 <ENT>
RE2100:  Displays:    'SP-32-3'
                   '  A.  '
```

CONTENTS

- 4. MECHANICAL DISASSEMBLING
- 4.1. ADJUSTMENTS AND MODULE LOCATION

4.1. MECHANICAL DISASSEMBLING AND MODULE LOCATION

1) Remove 2x allan screws.
 2) Remove arial connector by unscrewing it.

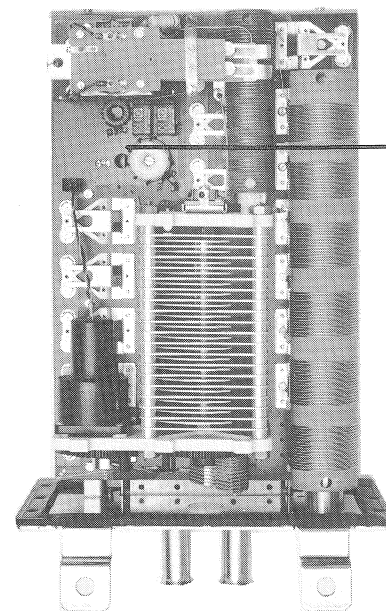
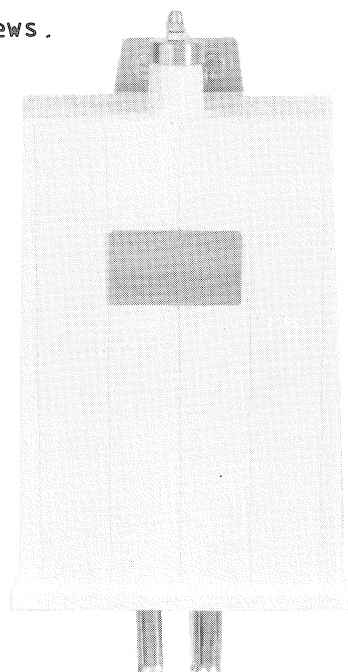
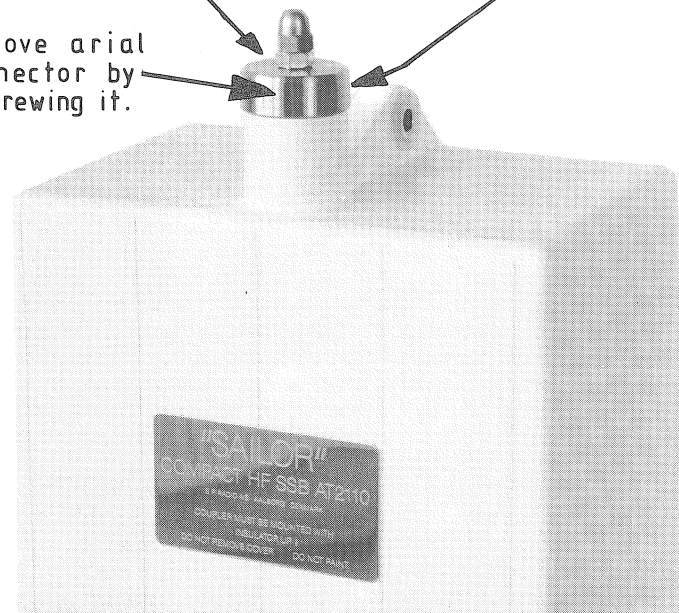

Main Board (Module 1)

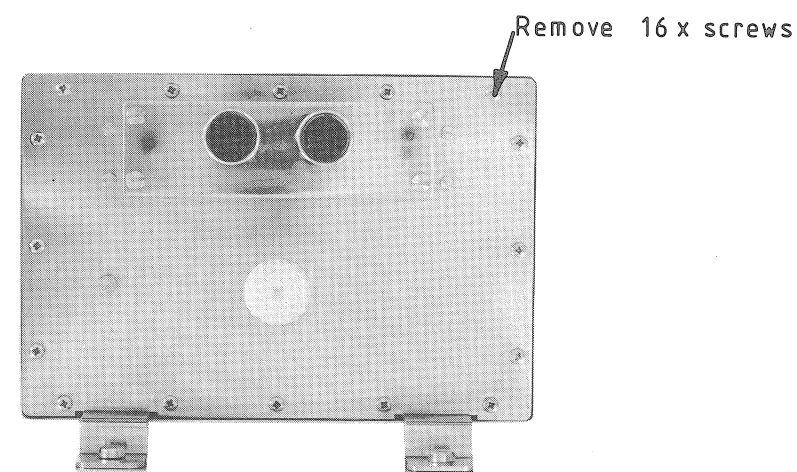
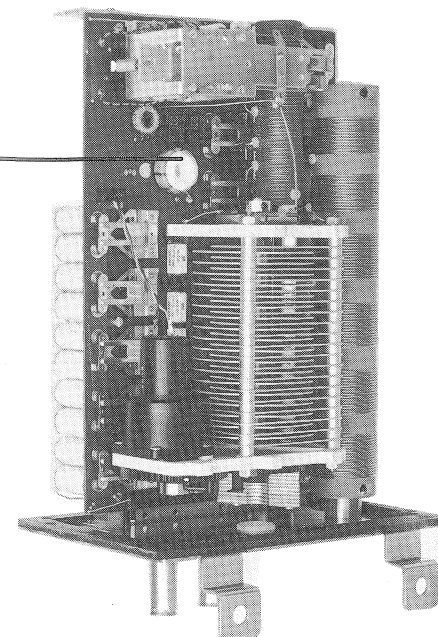

Bottom View

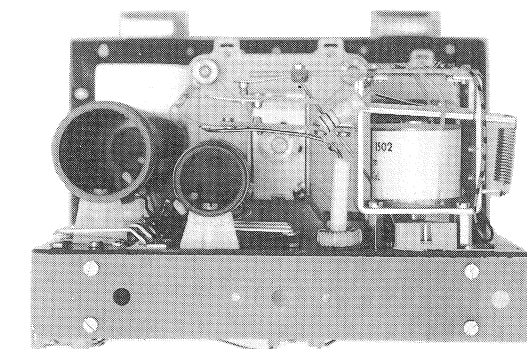

Top View

Connection and Interface (Module 3)

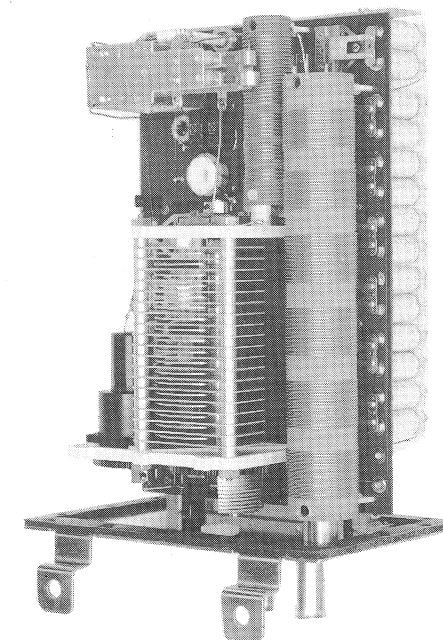
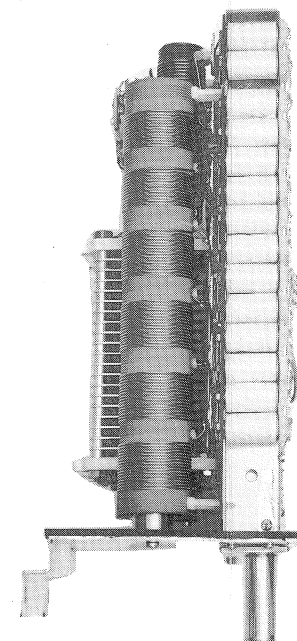
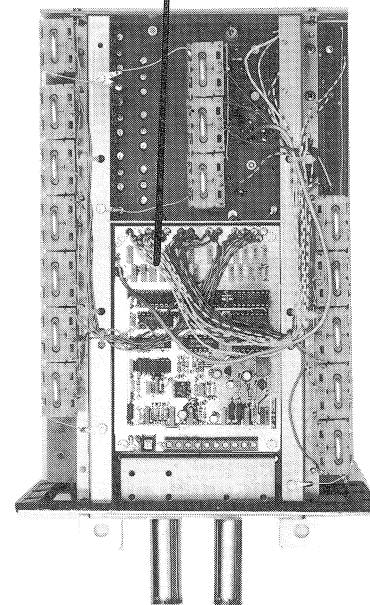
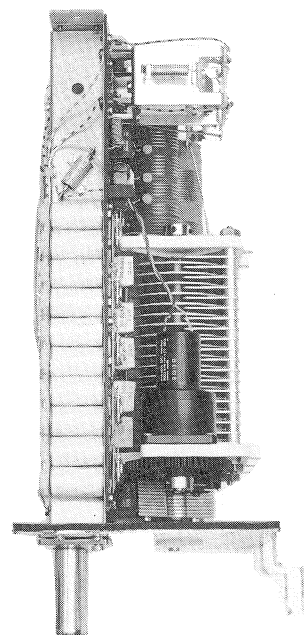

CONTENTS

- 5 **CIRCUIT DESCRIPTION AND SCHEMATIC DIAGRAMS**
- 5.1 **MAIN BOARD (MODULE 1) SP NO. 625651**
- 5.3 **CONNECTION AND INTERFACE UNIT (MODULE 3)
SP NO. 625653**

5 CIRCUIT DESCRIPTION AND SCHEMATIC DIAGRAMS

5.1 MAIN BOARD (MODULE 1) SP NO. 625651

This board contains all circuits necessary to make match between the aerial impedance and the transmitter output impedance.

In receive mode the signal is fed direct to the aerial via RE18, RE17, and RE16 for frequencies above 4 MHz. For frequencies below 4 MHz, RE17 is activated so that the aerial is fed through TR03 to the receiver. TR03 is transforming the aerial impedance down to give better match to the receiver.

In transmit mode the signal from the transmitter is fed to TR01, which transforms the impedance down to 12.5 ohm. From TR01 the signal is fed to L01 and L02. The value of the coils is set by the relays RE01 and RE10. The relays are controlled from the TX processor in T2130. From the coils the signal is fed to C01, a variable capacitor which is driven by the motor MO01. MO01 is controlled from the TX processor in T2130. The optocoupler OC01 gives a pulse for every 180o rotation of the capacitor C01. This pulse is fed to the TX processor in T2130. From the variable capacitor C01 the signal is fed to a shunt capacitor bank. The value is selected by RE11 to RE15, which is controlled from the TX processor in T2130. From the capacitor bank the signal is fed through TR02, which is a current transformer. The output from TR02 is rectified in D01 and the DC output is fed to the TX processor in T2130.

From TR02 the signal is fed to the aerial relay RE16. GL01 is protecting the aerial coupler against small lightnings. R02 is discharging the aerial.

COMPONENT LOCATION MAIN BOARD MODULE 1

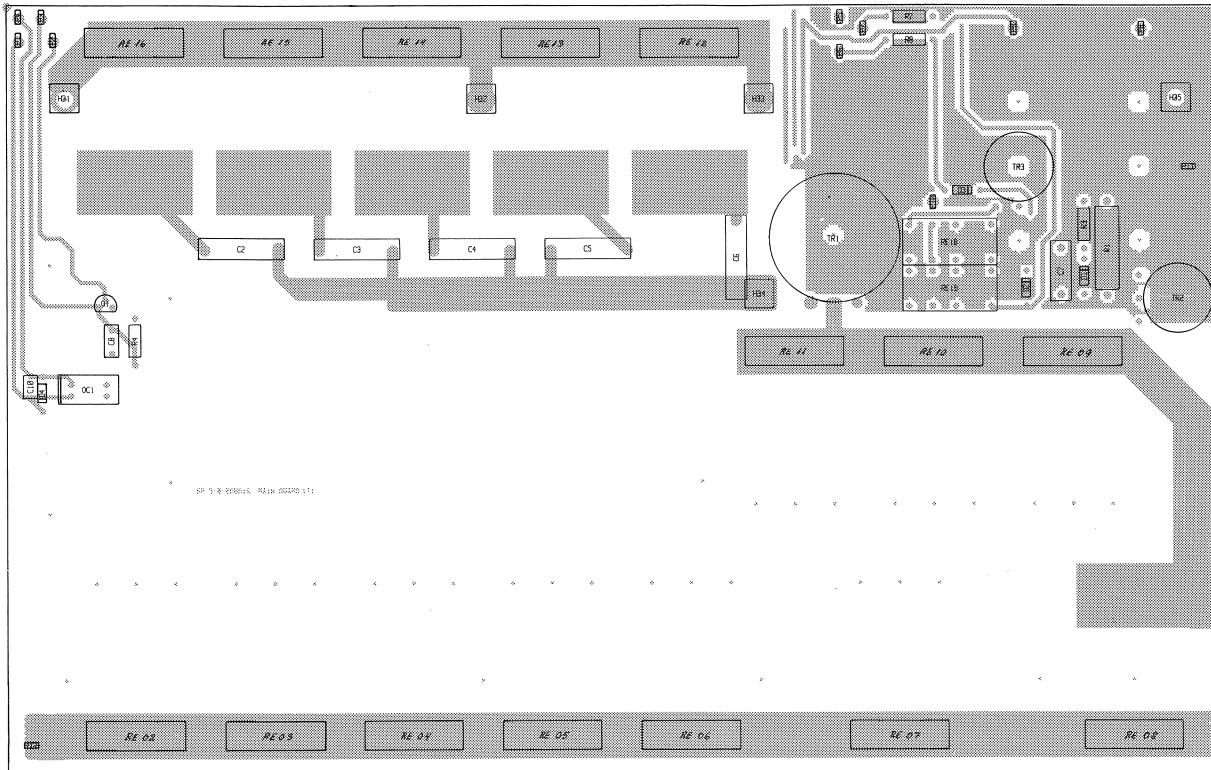

View from component side with upper side tracks.

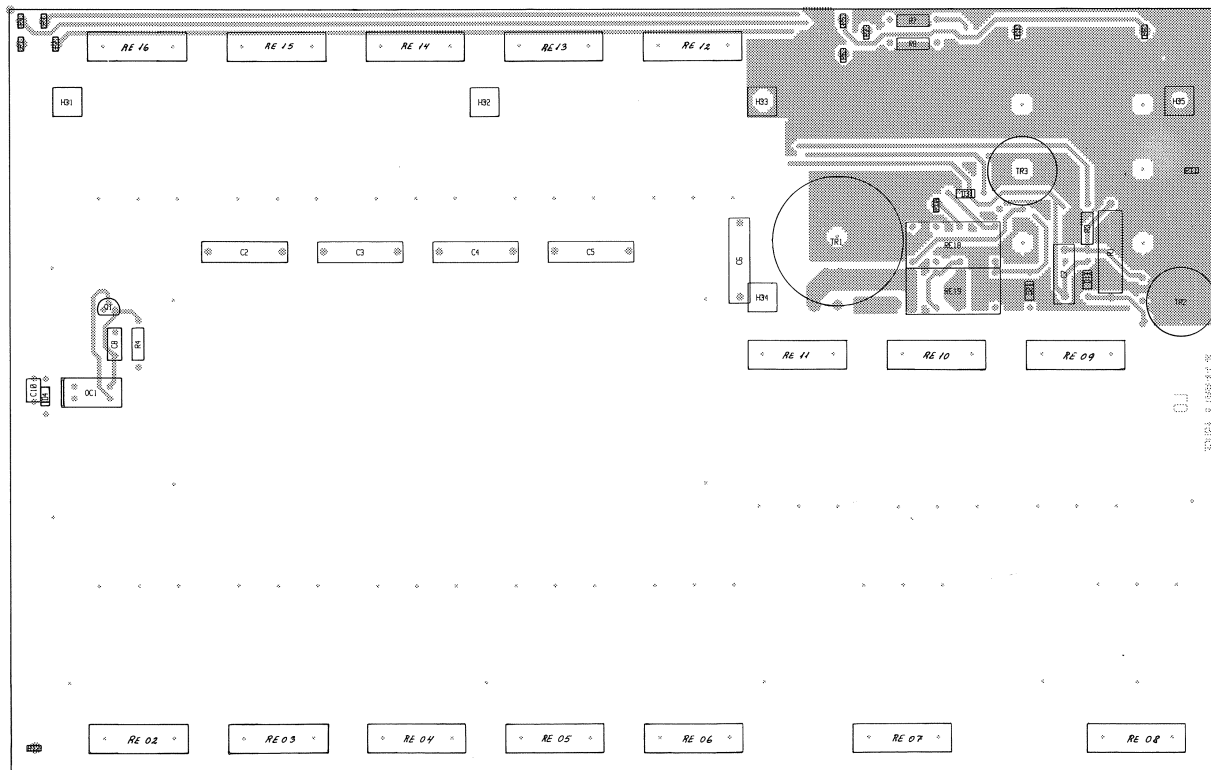

View from component side with lower side tracks.

MAIN BOARD MODULE 1

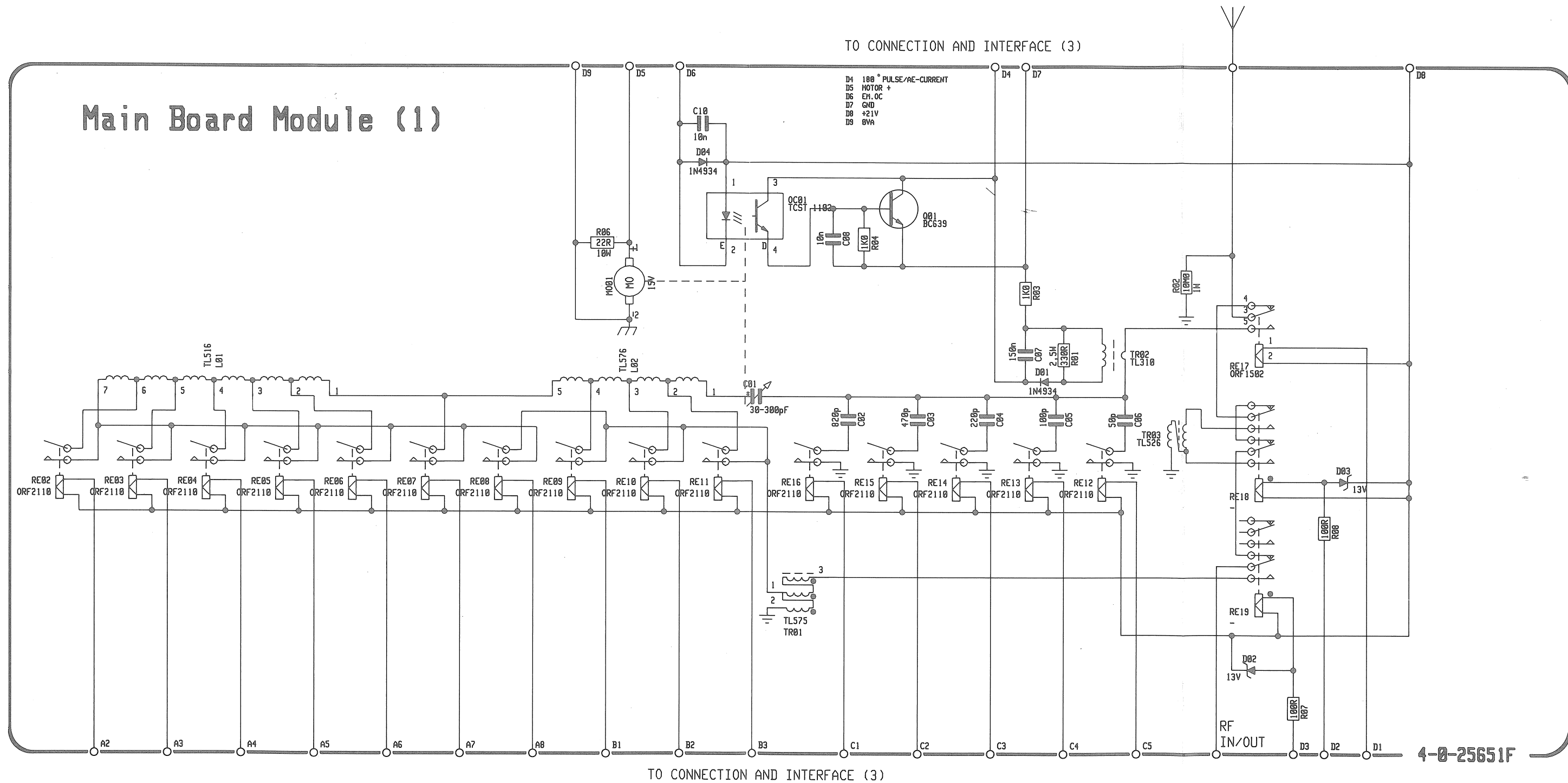

This diagram is valid for PCB rev. 25651G

5.3 CONNECTION AND INTERFACE UNIT (MODULE 3) SP NO. 625653

TECHNICAL DESCRIPTION

The Connection and Interface Board has the following main functions:

- receives data from the T2130
- activates the relays
- detects when manual tune is activated and activates specific relays

The circuit consists of the following subcircuits:

- PULSE SHAPING AND NOISE REDUCTION
- STROBE GENERATION
- POWER-UP RESET
- SHIFT REGISTERS
- RELAY DRIVERS
- MANUAL TUNE
- +5 VOLT REGULATOR

PULSE SHAPING AND NOISE REDUCTION

The board receives data synchronized. For every data bit is one separate clock bit.

There are two identical circuits for receiving and shaping clock and data pulses.

Each consists of a comparator U01 configured as a Schmitt-trigger. The reference is determined by the zener diode D06 and the hysteresis is determined by R10, R12, R06, and R11, R13, R28 respectively.

The lower trigger level is approximately 2.5 Volt and the upper trigger level is approximately 13.6 Volt.

To ensure a correct level for the following logic circuit, the Schmitt-triggers U03/04 and U03/01 (74HC14) are added.

STROBE GENERATION

To set data in the 3 serial to parallel shift registers, 24 clock pulses are necessary.

24 clock pulses and corresponding data are transmitted to the board twice with a certain period in between.

In the following, reference is made to 'Timing diagram for strobe generation'.

A strobe is generated when the board has received 24 clock pulses. The strobe is generated by use of a ripple counter U06 (74HC4024). When the outputs 'Q4' and 'Q5' ('8' and '16') both go to high level, the shift registers are strobed, the new data is transferred to the relay drivers, and the corresponding relays are activated.

The monostable U05/01, A1 (pin 4) is triggered when the strobe goes high.

The output of U05/01, Q1 (pin 6) goes high immediately and goes low after the time t_1 .

The ripple counter U06 is reset after the time t_1 and the second pulse train may be received.

The reset pulse comes from the monostable U05/02 pin 10, which is triggered when the time t_1 has passed U05/01, Q1 (pin 6) goes back to the low state.

The double clock and data transfer ensures a high security for the correct data transfer. Only in the time t_4 it is possible to introduce false clock pulses which may disturb the circuitry.

5.3 CONNECTION AND INTERFACE UNIT (MODULE 3) cont.:

Figure 1: Timing diagram for strobe generation.

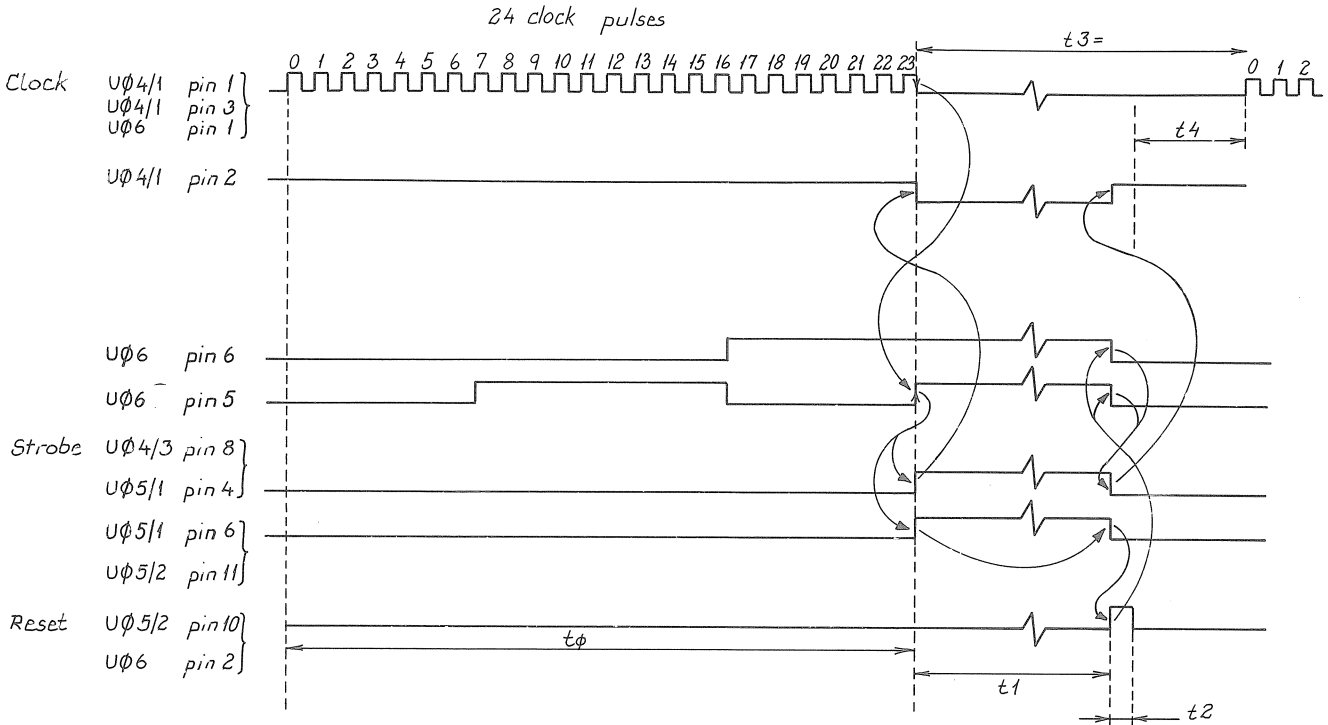

26041 Timing diagram for strobe generation.

All times are in msec. The parenthesis indicates how the time is determined.

- t_0 = 3.2 msec (microprocessor)
- t_1 min. = 2.93 msec
- t_1 max. = 3.78 msec (R19, C15, 'K' from 74HC4538)
- t_2 approx. = 0.01 msec. (R18, C14)
- t_3 = 4.0 msec (microprocessor)
- t_4 max. = 1.07 msec. ($t_3 - t_1$ max)
- t_4 min. = 0.22 msec. ($t_3 - t_1$ min)

POWER-UP RESET

This circuit delivers a pulse to the monostable U05/02, pin 12 when the power supply comes up. The output of the monostable gives a reset pulse to the ripple counter so it is ready to receive the 24 clock pulses.

SHIFT REGISTERS

The serial to parallel shift registers U09, U08, U07 (74HC595) are cascaded. When the data has been clocked to the correct bits by the 24 clock pulses, the strobe activates the 'Latch clock' input (pin 12) and the data is latched to the output.

RELAY DRIVERS

The relay drivers consist of 19 (2 spares) open collector Darlington drivers, located in U10, U11, and U12 (MC1413/ULN2003). Input of the drivers are connected to the output from the shift registers U07, U08, U09.

The output of the drivers are connected to the corresponding 19 relays.

The relay RE01 is normally released as the 'Date' wire is held low by TX-processor (3) in the T2130.

5.3 CONNECTION AND INTERFACE UNIT (MODULE 3) cont.:

MANUAL TUNE

When the 'Automatic/manual tune' switch on the Connection Board (6) in the T2130 is shifted to 'Manual Tune' two signals are changed.

Figure 2: Manual Tuning Overview.

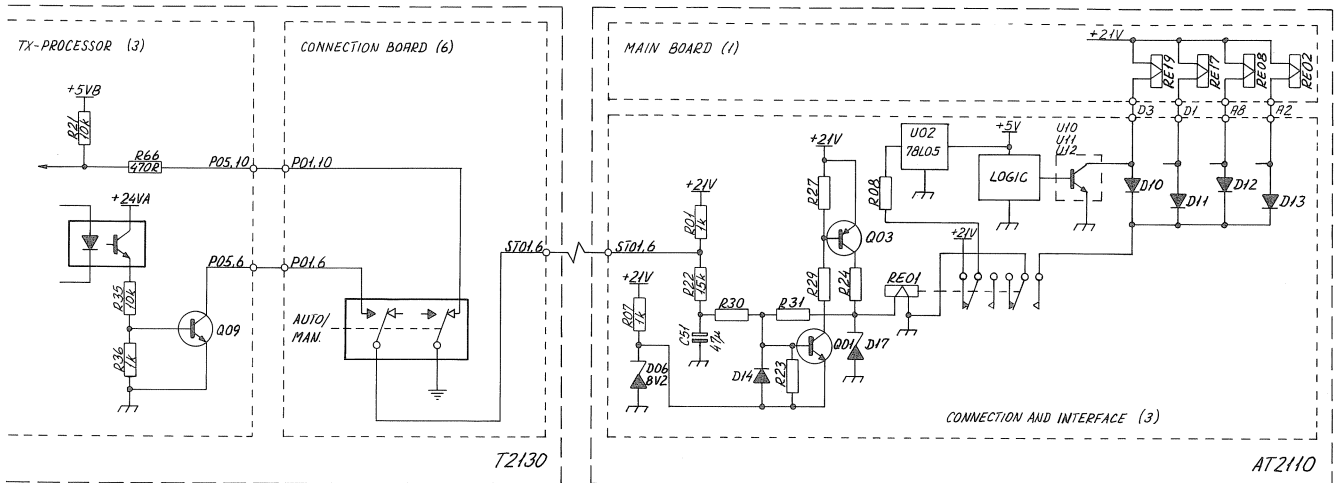

Manual Tuning Overview.

26042B

The 'Manual Tune' wire (P01 pin 10 on the Connection Board (6) and P05 pin 10 on the TX-processor (3, T2130)) is set to 0 Volt. This tells the TX-processor (3, T2130) (and the RE2100) that a manual tune is to be done and tune tones are started.

The 'Data' wire (ST01 pin 6 in the Connection Board (6) in T2130) is interrupted. The 'Data' line is normally kept low (<+1 Volt) when no data is transferred to the AT2110. The 'Data' wire is shifting to a high state (approx. +21 Volt) by the resistor R03 on the Connection and Interface Board (3) in the AT2110. This permanent shift of the 'Data' wire is detected by the 'Manual Tune' circuit. The capacitor C51 is slowly charged by the resistor R22. The relay RE01 is activated when the voltage on the C51 has reached approximately 12 Volt. The transistors Q01 and Q03 conform a Schmitt-trigger.

The activating of the relay RE01 disconnects the +21 for the U02, +5V supply for the logic. This means that all relays on the Main Board (1) are released from the drivers U10, U11, and U12.

The specific relays for tuning 2182 kHz are activated by the relay RE01 and the diodes D10 (RE19), D11 (RE17), D12 (RE08), D13 (RE02).

+5 VOLT REGULATOR

This regulator delivers the supply for the logic circuits on the Connection and Interface Board (3).

Part of 'Motor Control Circuitry'. This consists of the transistor Q02 and surrounding resistors R05, R25, R26. The transistor turns on the LED in the optocoupler OC01 on the Main Board (1) when supply voltage is applied to the tune motor MO1.

COMPONENT LOCATION CONNECTION AND INTERFACE UNIT MODULE 3

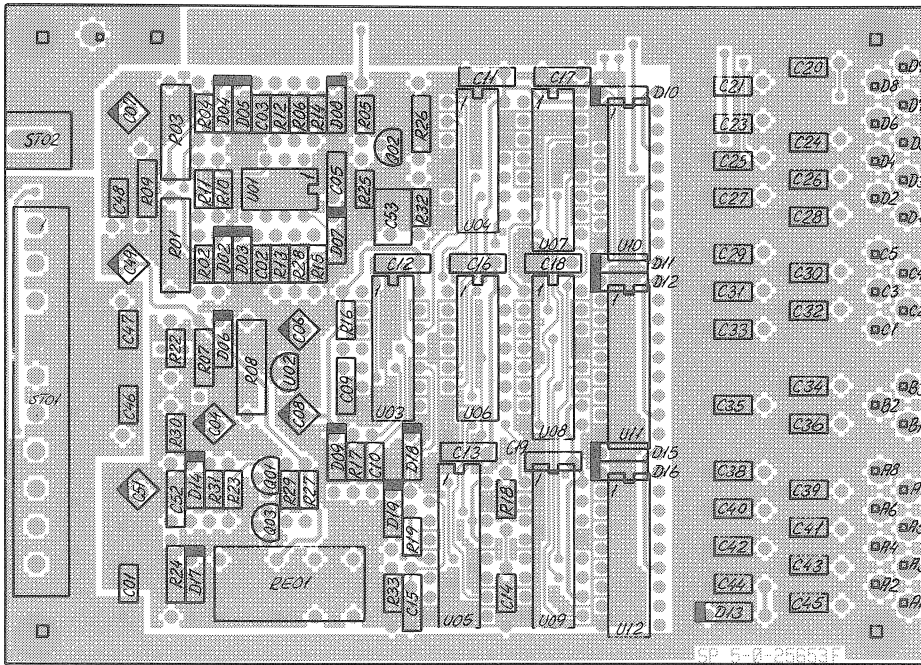

View from component side with upper side tracks.

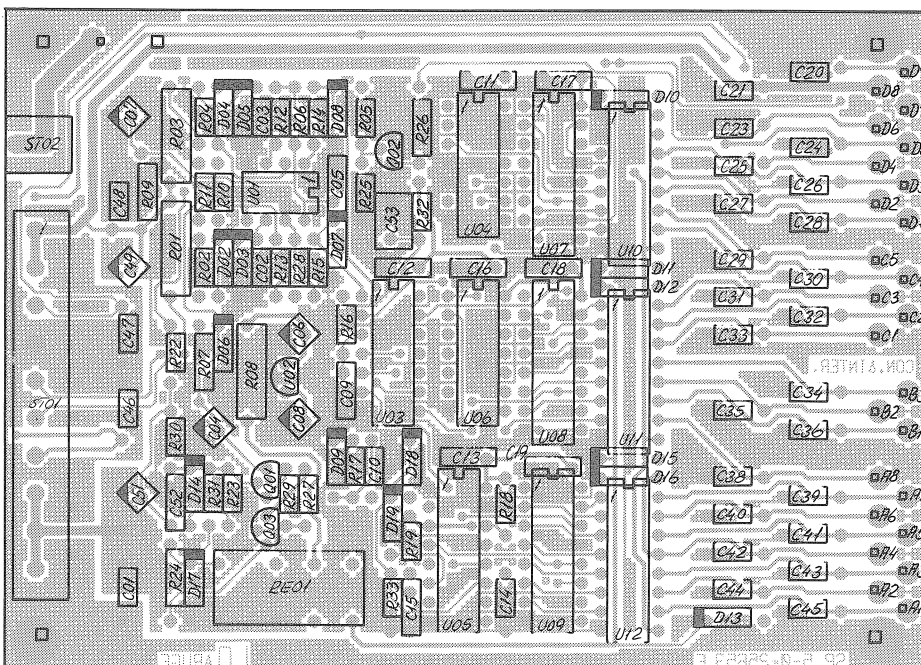

View from component side with lower side tracks.

CONNECTION AND INTERFACE UNIT MODULE 3

Connection and Interface (3)

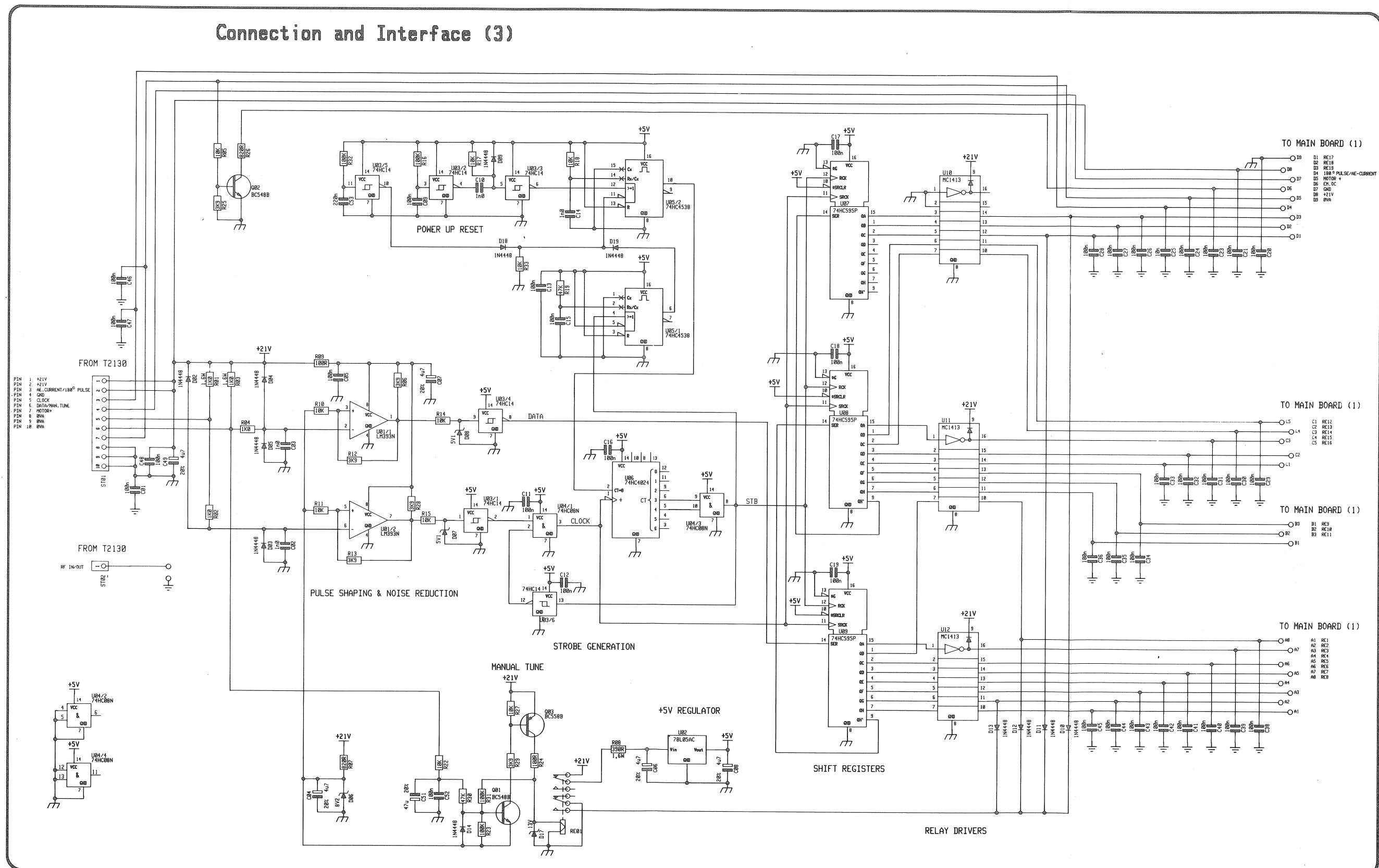

4-8-25653F

This diagram is valid for PCB rev. 25653F

CONTENTS

6. PARTS LIST

6 PARTS LIST

HF SSB AT2110		AERIAL COUPLER		ESPERA	HF SSB AT2110	802110
POSITION	DESCRIPTION			MANUFACTURER	TYPE	S.P.NUMBER
VARIOUS	MANUAL AT2110 ENGLISH			S.P.RADIO A/S		M2110GB
BASE UNIT AT2110				ESPERA		702110
POSITION	DESCRIPTION			MANUFACTURER	TYPE	S.P.NUMBER
VARIOUS	MAIN WIRING AT2110			ESPERA	3-0-26093B	526093
VARIOUS				ESPERA	526169 KABLING f. AT2110	526169
-1	MAIN BOARD MODULE 1	AT2110		ESPERA	5-0-25651G / 4-0-25651F	625651
-3	CONNECTION & INTERFACE	MODULE 3 AT2110		ESPERA	5-0-25653G / 4-0-25653G	625653
R2-1	RESISTOR HIGH VOLTAGE	10M OHM 10% 10kVDC		PHILIPS	2322 244 13106	06.050
R6-1	RESISTOR WIRE WOUND	22 OHM 5% 10W		ARCOL	HS-10-22R-5%	06.357
MAIN BOARD MODULE 1		AT2110		ESPERA	5-0-25651G / 4-0-25651F	625651
POSITION	DESCRIPTION			MANUFACTURER	TYPE	S.P.NUMBER
C1-1	VARIABLE CAPACITOR	AERIAL COUPLER AT2110		SP.RADIO A/S	3-0-25840	725840
C2-1	CAPACITOR CERAMIC	820pF 10% 2kVDC		UNILATOR	102/1/8200K/EJO	18.190
C3-1	CAPACITOR CERAMIC	470pF 10% 2kVDC		UNILATOR	102/1/4700K/EJO	18.185
C4-1	CAPACITOR CERAMIC	220pF 10% 2kVDC		UNILATOR	102/1/2200K/EJO	18.180
C5-1	CAPACITOR CERAMIC	100pF 10% 2kVDC		UNILATOR	102/1/1000K/EJO	18.175
C6-1	CAPACITOR CERAMIC	50pF 10% 2kVDC		UNILATOR	102/1/0500K/EJO	18.170
C7-1	CAPACITOR POLYESTER	150nF 10% 100VDC		PHILIPS	2222 372 21154	11.074
C8-1	CAPACITOR CERAMIC	10nF -20/+80% CL2 50VDC		NKE	DT 350 758L F 103 Z 50V	15.170
C10-1	CAPACITOR CERAMIC	10nF -20/+80% 50VDC CL2		KEMET	C 317 C 103 Z 5U5CA-C7301	16.302
D1-1	DIODE HIGH SPEED	1N4448		PHILIPS	1N4448	25.147
D2-1	DIODE ZENER	13V 5% 0.4W BZX79C13		PHILIPS	BZX79C13	26.560
D3-1	DIODE ZENER	13V 5% 0.4W BZX79C13		PHILIPS	BZX79C13	26.560
D4-1	DIODE HIGH SPEED	1N4448		PHILIPS	1N4448	25.147
L1-1	COIL TL516			ESPERA	6-0-25789C	400516
L2-1	CHOKE TL576			ESPERA	6-0-28021	400576
M01-1	MOTOR W. GEARBOX	C1065		MAXON	SP SPEC.: C1065	60.010
OC1-1	PHOTO INTERRUPTER			TELEFUNKEN	TCST 1103	32.521
Q1-1	TRANSISTOR AF	NPN BC639 TO-92		PHILIPS	BC639	28.120
R1-1	RESISTOR PMF	330 OHM 5% 3W		PHILIPS	2322 195 13331	04.687
R3-1	RESISTOR MF	1k0 OHM 5% 0.4W		PHILIPS	2322 181 53102	01.200
R4-1	RESISTOR MF	1k0 OHM 5% 0.4W		PHILIPS	2322 181 53102	01.200
R7-1	RESISTOR MF	100 OHM 5% 0.4W		PHILIPS	2322 181 53101	01.175
R8-1	RESISTOR MF	100 OHM 5% 0.4W		PHILIPS	2322 181 53101	01.175
RE2-1	RELAY ORF2110	FOR SERVICE ONLY		ESPERA	3-0-25810A / 4-0-26184	725810
RE3-1	RELAY ORF2110	FOR SERVICE ONLY		ESPERA	3-0-25810A / 4-0-26184	725810
RE4-1	RELAY ORF2110	FOR SERVICE ONLY		ESPERA	3-0-25810A / 4-0-26184	725810
RE5-1	RELAY ORF2110	FOR SERVICE ONLY		ESPERA	3-0-25810A / 4-0-26184	725810
RE6-1	RELAY ORF2110	FOR SERVICE ONLY		ESPERA	3-0-25810A / 4-0-26184	725810
RE7-1	RELAY ORF2110	FOR SERVICE ONLY		ESPERA	3-0-25810A / 4-0-26184	725810
RE8-1	RELAY ORF2110	FOR SERVICE ONLY		ESPERA	3-0-25810A / 4-0-26184	725810
RE9-1	RELAY ORF2110	FOR SERVICE ONLY		ESPERA	3-0-25810A / 4-0-26184	725810
RE10-1	RELAY ORF2110	FOR SERVICE ONLY		ESPERA	3-0-25810A / 4-0-26184	725810
RE11-1	RELAY ORF2110	FOR SERVICE ONLY		ESPERA	3-0-25810A / 4-0-26184	725810
RE12-1	RELAY ORF2110	FOR SERVICE ONLY		ESPERA	3-0-25810A / 4-0-26184	725810
RE13-1	RELAY ORF2110	FOR SERVICE ONLY		ESPERA	3-0-25810A / 4-0-26184	725810
RE14-1	RELAY ORF2110	FOR SERVICE ONLY		ESPERA	3-0-25810A / 4-0-26184	725810
RE15-1	RELAY ORF2110	FOR SERVICE ONLY		ESPERA	3-0-25810A / 4-0-26184	725810
RE16-1	RELAY ORF2110	FOR SERVICE ONLY		ESPERA	3-0-25810A / 4-0-26184	725810
RE17-1	RELAY	ORF1502		ESPERA	ORF1502 SKIFTERELÆ	705061
RE18-1	RELAY 12VDC DPDT 1.25A	M1B-12-H/AZ 820-2C212DE		MEISEI	M1B-12-H	21.295
RE19-1	RELAY 12VDC DPDT 1.25A	M1B-12-H/AZ 820-2C212DE		MEISEI	M1B-12-H	21.295
TR1-1	TRANSFORMER 9:1	TL575		S.P.RADIO	6-0-28020	400575
TR2-1	TRANSFORMER	TL310		BB	6-0-23162E	400310
TR3-1	TRANSFORMER	TL526		S.P.RADIO	6-0-25867B	400526

POSITION	DESCRIPTION	MANUFACTOR	TYPE	S.P.NUMBER	
CONNECTION & INTERFACE		MODULE 3 AT2110	ESPERA	5-0-25653G/4-0-25653G	625653
POSITION	DESCRIPTION	MANUFACTOR	TYPE	S.P.NUMBER	
C1-3	CAPACITOR MKT	100nF 10% 100VDC	PHILIPS	2222 371 28104	11.180
C2-3	CAPACITOR MKT	1000pF 10% 400VDC	SIEMENS	B32520-A6102-K-289	11.139
C3-3	CAPACITOR MKT	1000pF 10% 400VDC	SIEMENS	B32520-A6102-K-289	11.139
C4-3	CAPACITOR ELECTROLYTIC	4.7uF 20% 50VDC	ELNA	RJ2-50-V-4R7-M-T34	14.510
C5-3	CAPACITOR MKT	0.1uF 10% 63VDC	PHILIPS	2222 370 78104	11.136
C6-3	CAPACITOR ELECTROLYTIC	4.7uF 20% 50VDC	ELNA	RJ2-50-V-4R7-M-T34	14.510
C7-3	CAPACITOR ELECTROLYTIC	4.7uF 20% 50VDC	ELNA	RJ2-50-V-4R7-M-T34	14.510
C8-3	CAPACITOR ELECTROLYTIC	4.7uF 20% 50VDC	ELNA	RJ2-50-V-4R7-M-T34	14.510
C9-3	CAPACITOR MKT	100nF 5% 63VDC	PHILIPS	2222 370 79104	11.135
C10-3	CAPACITOR MKT	1000pF 10% 400VDC	SIEMENS	B32520-A6102-K-289	11.139
C11-3	CAPACITOR MKT	0.1uF 10% 63VDC	PHILIPS	2222 370 78104	11.136
C12-3	CAPACITOR MKT	0.1uF 10% 63VDC	PHILIPS	2222 370 78104	11.136
C13-3	CAPACITOR MKT	0.1uF 10% 63VDC	PHILIPS	2222 370 78104	11.136
C14-3	CAPACITOR MKT	1000pF 10% 400VDC	SIEMENS	B32520-A6102-K-289	11.139
C15-3	CAPACITOR MKT	100nF 5% 63VDC	PHILIPS	2222 370 79104	11.135
C16-3	CAPACITOR MKT	0.1uF 10% 63VDC	PHILIPS	2222 370 78104	11.136
C17-3	CAPACITOR MKT	0.1uF 10% 63VDC	PHILIPS	2222 370 78104	11.136
C18-3	CAPACITOR MKT	0.1uF 10% 63VDC	PHILIPS	2222 370 78104	11.136
C19-3	CAPACITOR MKT	0.1uF 10% 63VDC	PHILIPS	2222 370 78104	11.136
C20-3	CAPACITOR MKT	100nF 10% 100VDC	PHILIPS	2222 371 28104	11.180
C21-3	CAPACITOR MKT	100nF 10% 100VDC	PHILIPS	2222 371 28104	11.180
C23-3	CAPACITOR MKT	100nF 10% 100VDC	PHILIPS	2222 371 28104	11.180
C24-3	CAPACITOR MKT	100nF 10% 100VDC	PHILIPS	2222 371 28104	11.180
C25-3	CAPACITOR MKT	10nF 10% 250VDC	PHILIPS	2222 371 48103	11.148
C26-3	CAPACITOR MKT	100nF 10% 100VDC	PHILIPS	2222 371 28104	11.180
C27-3	CAPACITOR MKT	100nF 10% 100VDC	PHILIPS	2222 371 28104	11.180
C28-3	CAPACITOR MKT	100nF 10% 100VDC	PHILIPS	2222 371 28104	11.180
C29-3	CAPACITOR MKT	100nF 10% 100VDC	PHILIPS	2222 371 28104	11.180
C30-3	CAPACITOR MKT	100nF 10% 100VDC	PHILIPS	2222 371 28104	11.180
C31-3	CAPACITOR MKT	100nF 10% 100VDC	PHILIPS	2222 371 28104	11.180
C32-3	CAPACITOR MKT	100nF 10% 100VDC	PHILIPS	2222 371 28104	11.180
C33-3	CAPACITOR MKT	100nF 10% 100VDC	PHILIPS	2222 371 28104	11.180
C34-3	CAPACITOR MKT	100nF 10% 100VDC	PHILIPS	2222 371 28104	11.180
C35-3	CAPACITOR MKT	100nF 10% 100VDC	PHILIPS	2222 371 28104	11.180
C36-3	CAPACITOR MKT	100nF 10% 100VDC	PHILIPS	2222 371 28104	11.180
C38-3	CAPACITOR MKT	100nF 10% 100VDC	PHILIPS	2222 371 28104	11.180
C39-3	CAPACITOR MKT	100nF 10% 100VDC	PHILIPS	2222 371 28104	11.180
C40-3	CAPACITOR MKT	100nF 10% 100VDC	PHILIPS	2222 371 28104	11.180
C41-3	CAPACITOR MKT	100nF 10% 100VDC	PHILIPS	2222 371 28104	11.180
C42-3	CAPACITOR MKT	100nF 10% 100VDC	PHILIPS	2222 371 28104	11.180
C43-3	CAPACITOR MKT	100nF 10% 100VDC	PHILIPS	2222 371 28104	11.180
C44-3	CAPACITOR MKT	100nF 10% 100VDC	PHILIPS	2222 371 28104	11.180
C45-3	CAPACITOR MKT	100nF 10% 100VDC	PHILIPS	2222 371 28104	11.180
C46-3	CAPACITOR MKT	100nF 10% 100VDC	PHILIPS	2222 371 28104	11.180
C47-3	CAPACITOR MKT	100nF 10% 100VDC	PHILIPS	2222 371 28104	11.180
C48-3	CAPACITOR MKT	100nF 10% 100VDC	PHILIPS	2222 371 28104	11.180
C49-3	CAPACITOR ELECTROLYTIC	4.7uF 20% 50VDC	ELNA	RJ2-50-V-4R7-M-T34	14.510
C51-3	CAPACITOR ELECTROLYTIC	47uF 20% 25VDC	ELNA	RJ2-25-V-470-M-F1	14.524
C52-3	CAPACITOR MKT	0.1uF 10% 63VDC	PHILIPS	2222 370 78104	11.136
C53-3	CAPACITOR MKT	220nF 10% 63VDC	PHILIPS	2222 370 78224	11.095
D2-3	DIODE HIGH SPEED	1N4448	PHILIPS	1N4448	25.147
D3-3	DIODE HIGH SPEED	1N4448	PHILIPS	1N4448	25.147
D4-3	DIODE HIGH SPEED	1N4448	PHILIPS	1N4448	25.147
D5-3	DIODE HIGH SPEED	1N4448	PHILIPS	1N4448	25.147
D6-3	DIODE ZENER	8V2 5% 0.4W BZX79C8V2	PHILIPS	BZX79C8V2	26.542
D7-3	DIODE ZENER	5.1V 5% 0.4W BZX79C5V1	PHILIPS	BZX79C5V1	26.527
D8-3	DIODE ZENER	5.1V 5% 0.4W BZX79C5V1	PHILIPS	BZX79C5V1	26.527
D9-3	DIODE HIGH SPEED	1N4448	PHILIPS	1N4448	25.147
D10-3	DIODE HIGH SPEED	1N4448	PHILIPS	1N4448	25.147
D11-3	DIODE HIGH SPEED	1N4448	PHILIPS	1N4448	25.147
D12-3	DIODE HIGH SPEED	1N4448	PHILIPS	1N4448	25.147
D13-3	DIODE HIGH SPEED	1N4448	PHILIPS	1N4448	25.147
D14-3	DIODE HIGH SPEED	1N4448	PHILIPS	1N4448	25.147
D17-3	DIODE ZENER	13V 5% 0.4W BZX79C13	PHILIPS	BZX79C13	26.560
D18-3	DIODE HIGH SPEED	1N4448	PHILIPS	1N4448	25.147

POSITION	DESCRIPTION		MANUFACTOR	TYPE	S.P.NUMBER
D19-3	DIODE HIGH SPEED	1N4448	PHILIPS	1N4448	25.147
D20-3	DIODE HIGH SPEED	1N4448	PHILIPS	1N4448	25.147
Q1-3	TRANSISTOR AF	BC548B NPN TO-92	PHILIPS	BC548B	28.076
Q2-3	TRANSISTOR AF	BC548B NPN TO-92	PHILIPS	BC548B	28.076
Q3-3	TRANSISTOR AF	BC558B	PHILIPS	BC558B	28.100
R1-3	RESISTOR PMF	1k0 OHM 5% 2W	PHILIPS	2322 194 13102	04.200
R2-3	RESISTOR MF	1k0 OHM 5% 0.33W	PHILIPS	2322 180 73102	02.472
R3-3	RESISTOR PMF	1k0 OHM 5% 2W	PHILIPS	2322 194 13102	04.200
R4-3	RESISTOR MF	1k0 OHM 5% 0.33W	PHILIPS	2322 180 73102	02.472
R5-3	RESISTOR MF	10k OHM 5% 0.33W	PHILIPS	2322 180 73103	02.496
R6-3	RESISTOR MF	3k9 OHM 5% 0.33W	PHILIPS	2322 180 73392	02.486
R7-3	RESISTOR MF	820 OHM 5% 0.4W	PHILIPS	2322 181 53821	01.197
R8-3	RESISTOR PMF	390 OHM 5% 2W	PHILIPS	2322 194 13391	04.189
R9-3	RESISTOR MF	100 OHM 5% 0.4W	PHILIPS	2322 181 53101	01.175
R10-3	RESISTOR MF	10k OHM 5% 0.33W	PHILIPS	2322 180 73103	02.496
R11-3	RESISTOR MF	10k OHM 5% 0.33W	PHILIPS	2322 180 73103	02.496
R12-3	RESISTOR MF	3k9 OHM 5% 0.33W	PHILIPS	2322 180 73392	02.486
R13-3	RESISTOR MF	3k9 OHM 5% 0.33W	PHILIPS	2322 180 73392	02.486
R14-3	RESISTOR MF	10k OHM 5% 0.33W	PHILIPS	2322 180 73103	02.496
R15-3	RESISTOR MF	10k OHM 5% 0.33W	PHILIPS	2322 180 73103	02.496
R16-3	RESISTOR MF	100k OHM 5% 0.33W	PHILIPS	2322 180 73104	02.520
R17-3	RESISTOR MF	10k OHM 5% 0.33W	PHILIPS	2322 180 73103	02.496
R18-3	RESISTOR MF	10k OHM 5% 0.33W	PHILIPS	2322 180 73103	02.496
R19-3	RESISTOR MF	47k OHM 5% 0.33W	PHILIPS	2322 180 73473	02.512
R22-3	RESISTOR MF	10k OHM 5% 0.33W	PHILIPS	2322 180 73103	02.496
R23-3	RESISTOR MF	100k OHM 5% 0.33W	PHILIPS	2322 180 73104	02.520
R24-3	RESISTOR MF	100 OHM 5% 0.4W	PHILIPS	2322 181 53101	01.175
R25-3	RESISTOR MF	3k9 OHM 5% 0.33W	PHILIPS	2322 180 73392	02.486
R26-3	RESISTOR MF	820 OHM 5% 0.4W	PHILIPS	2322 181 53821	01.197
R27-3	RESISTOR MF	10k OHM 5% 0.33W	PHILIPS	2322 180 73103	02.496
R28-3	RESISTOR MF	3k9 OHM 5% 0.33W	PHILIPS	2322 180 73392	02.486
R29-3	RESISTOR MF	3k9 OHM 5% 0.33W	PHILIPS	2322 180 73392	02.486
R30-3	RESISTOR MF	47k OHM 5% 0.33W	PHILIPS	2322 180 73473	02.512
R31-3	RESISTOR MF	100k OHM 5% 0.33W	PHILIPS	2322 180 73104	02.520
R32-3	RESISTOR MF	100k OHM 5% 0.33W	PHILIPS	2322 180 73104	02.520
R33-3	RESISTOR MF	10k OHM 5% 0.33W	PHILIPS	2322 180 73103	02.496
RE1-3	RELAY 12VDC DPDT 1.25A	M1B-12-H/AZ 820-2C212DE	MEISEI	M1B-12-H	21.295
ST1-3	TERMINAL BLOCK	10 POLES 1.5mm2	PTR	AK300/10b m.MESS.SKRUER	81.017
ST2-3	TERMINAL BLOCK	SINGLE POLE	RIACON	360291	81.028
U1-3	DUAL DIFF.COMPARATOR	LM393	TEXAS	LM393P	31.105
U2-3	POS. VOLTAGE REG. FIXED	5V 5% 0.1A 78L05AC	MOTOROLA*	MC78L05ACP	31.135
U3-3	INVERTER w.SCHMIDT TRIGG.	74HC14	TEXAS	SN74HC14	34.518
U4-3	QUAD 2-INP.POS.AND GATE	74HC08	TEXAS	SN74HC08N	34.517
U5-3	MONOSTAB.MULTIVIB.DUAL	74HC4538	MOTOROLA	MC74HC4538AN	34.563
U6-3	COUNTER 7 STATE BIN.RIPP.	74HC4024	TEXAS	SN74HC4024	34.555
U7-3	8 BIT SHIFT REG.SERIAL IO	74HC595	NATIONAL	MM74HC595N	34.502
U8-3	8 BIT SHIFT REG.SERIAL IO	74HC595	NATIONAL	MM74HC595N	34.502
U9-3	8 BIT SHIFT REG.SERIAL IO	74HC595	NATIONAL	MM74HC595N	34.502
U10-3	DARL.DRIVERS HI.CURR/VOLT	ULN2003/MC1413/L203	TEXAS	ULN2003A	31.077
U11-3	DARL.DRIVERS HI.CURR/VOLT	ULN2003/MC1413/L203	TEXAS	ULN2003A	31.077
U12-3	DARL.DRIVERS HI.CURR/VOLT	ULN2003/MC1413/L203	TEXAS	ULN2003A	31.077

